

ELECTROSTATIC SENSITIVE DEVICE
OBSERVE HANDLING PRECAUTIONS

MITSUBISHI RF POWER MOS FET

RD70HVF1

Silicon MOSFET Power Transistor, 175MHz70W 520MHz,50W

DESCRIPTION

RD70HVF1 is a MOS FET type transistor specifically designed for VHF/UHF High power amplifiers applications.

FEATURES

- High power and High Gain:
Pout>70W, Gp>10.6dB @Vdd=12.5V,f=175MHz
Pout>50W, Gp>7.0dB @Vdd=12.5V,f=520MHz
- High Efficiency: 60%typ.on VHF Band
- High Efficiency: 55%typ.on UHF Band

APPLICATION

For output stage of high power amplifiers in VHF/UHF Band mobile radio sets.

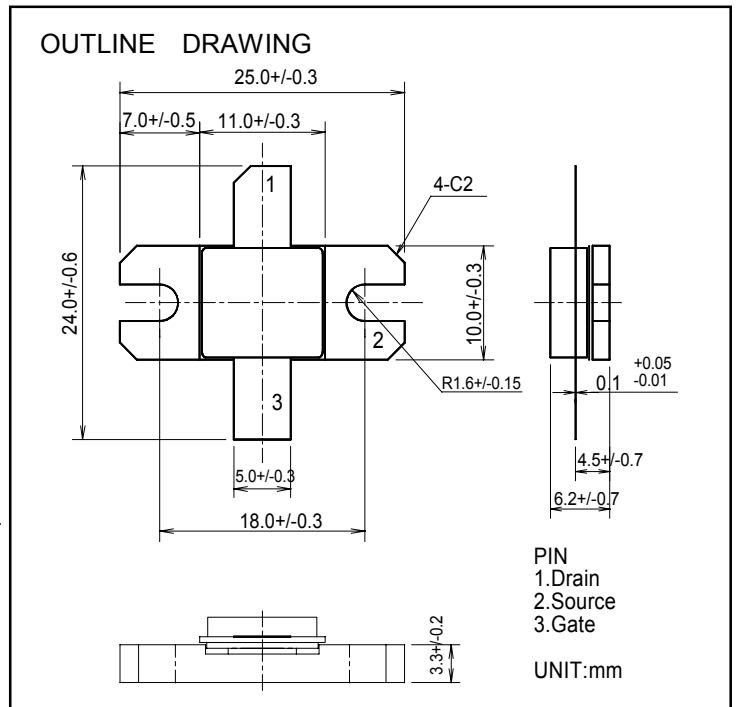

ABSOLUTE MAXIMUM RATINGS

(Tc=25°C UNLESS OTHERWISE NOTED)

SYMBOL	PARAMETER	CONDITIONS	RATINGS	UNIT
VDSS	Drain to source voltage		30	V
VGSS	Gate to source voltage		+/-20	V
Pch	Channel dissipation	Tc=25°C	150	W
Tj	Junction Temperature		175	°C
Tstg	Storage temperature		-40 to +175	°C
Rth-c	Thermal resistance	Junction to case	1.0	°C/W

Note 1: Above parameters are guaranteed independently.

ELECTRICAL CHARACTERISTICS (Tc=25°C, UNLESS OTHERWISE NOTED)

SYMBOL	PARAMETER	CONDITIONS	LIMITS			UNIT
			MIN	TYP	MAX.	
IDSS	Zerogate voltage drain current	VDS=17V, VGS=0V	-	-	300	uA
IGSS	Gate to source leak current	VGS=10V, VDS=0V	-	-	1	uA
VTH	Gate threshold voltage	VDS=12V, IDS=1mA	1.3	1.8	2.3	V
Pout	Output power	f=175MHz, VDD=12.5V	70	75	-	W
ηD	Drain efficiency	Pin=6W, Idq=2.0A	55	60	-	%
Pout	Output power	f=520MHz, VDD=12.5V	50	55	-	W
ηD	Drain efficiency	Pin=10W, Idq=2.0A	50	55	-	%
	Load VSWR tolerance	VDD=15.2V, Po=70W (PinControl) f=175MHz, Idq=2.0A, Zg=50Ω Load VSWR=20:1 (All phase)	No destroy			-
	Load VSWR tolerance	VDD=15.2V, Po=50W (PinControl) f=520MHz, Idq=2.0A, Zg=50Ω Load VSWR=20:1 (All phase)	No destroy			-

Note : Above parameters, ratings, limits and conditions are subject to change.



ELECTROSTATIC SENSITIVE DEVICE
OBSERVE HANDLING PRECAUTIONS

MITSUBISHI RF POWER MOS FET

RD70HVF1

Silicon MOSFET Power Transistor, 175MHz70W 520MHz,50W

TYPICAL CHARACTERISTICS

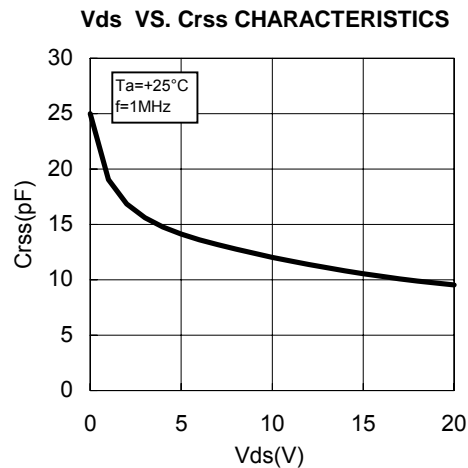
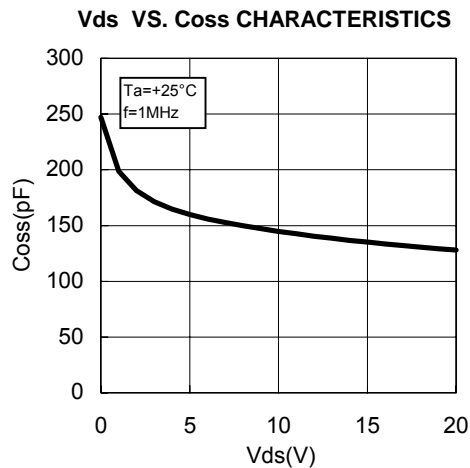
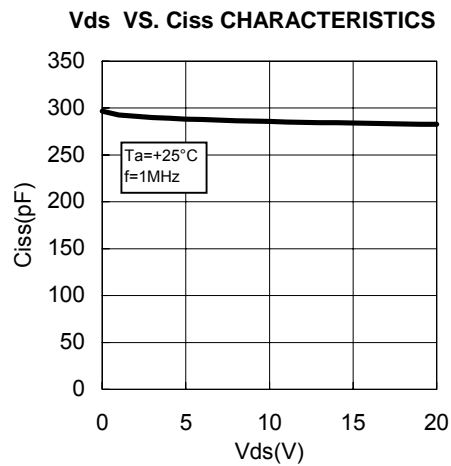
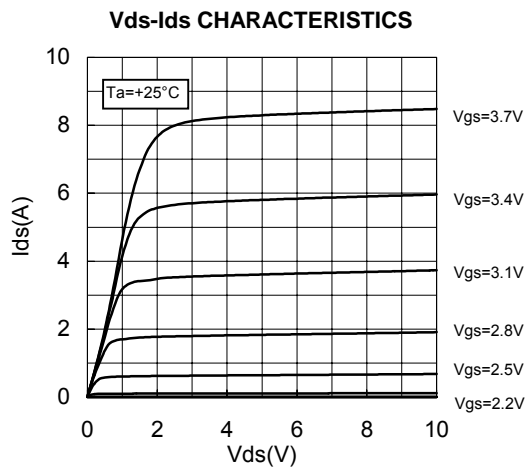
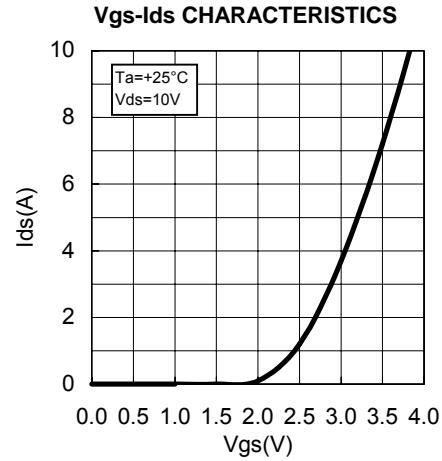
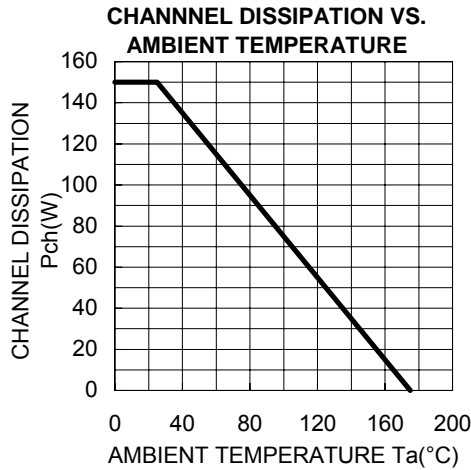



ELECTROSTATIC SENSITIVE DEVICE
OBSERVE HANDLING PRECAUTIONS

MITSUBISHI RF POWER MOS FET

RD70HVF1

Silicon MOSFET Power Transistor, 175MHz70W 520MHz,50W

TYPICAL CHARACTERISTICS

Pin-Po CHARACTERISTICS
@f=175MHz

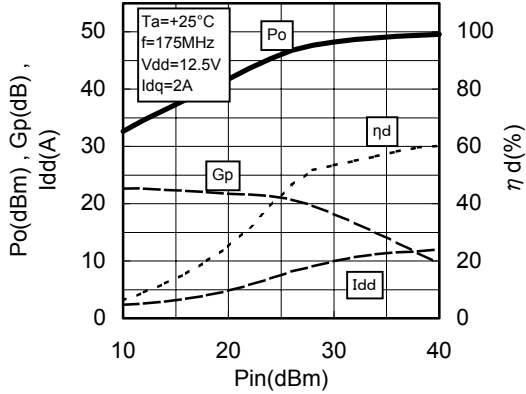

Pin-Po CHARACTERISTICS
@f=175MHz

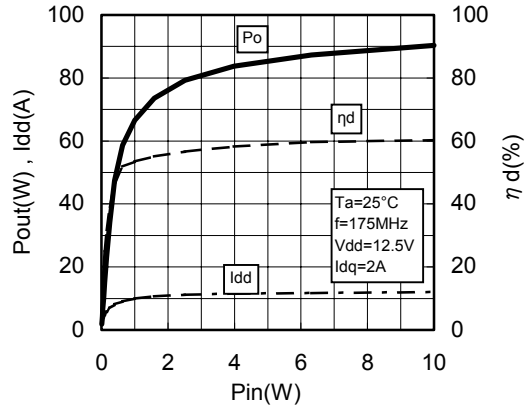

Pin-Po CHARACTERISTICS
@f=520MHz

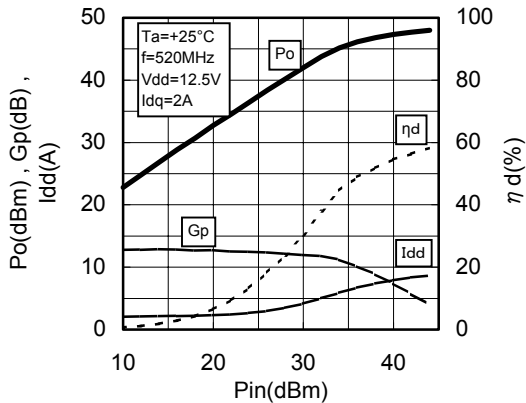

Pin-Po CHARACTERISTICS
@f=520MHz

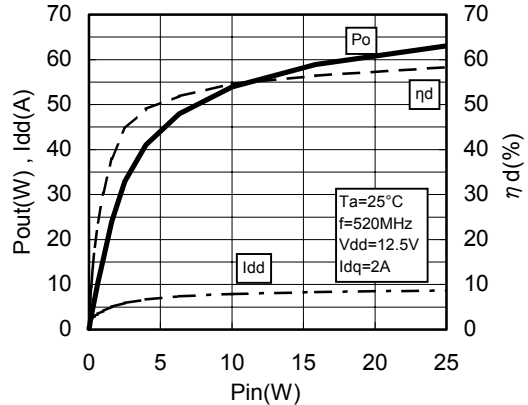

Vdd-Po CHARACTERISTICS
@f=175MHz

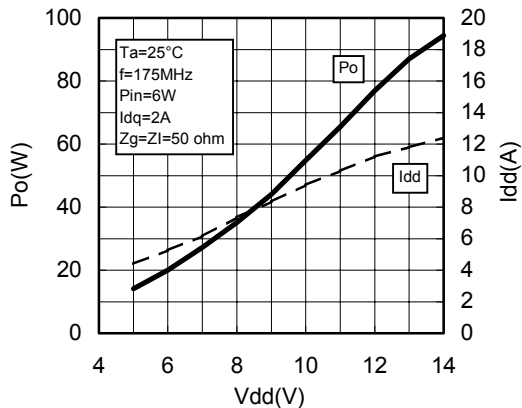

Vdd-Po CHARACTERISTICS
@f=520MHz

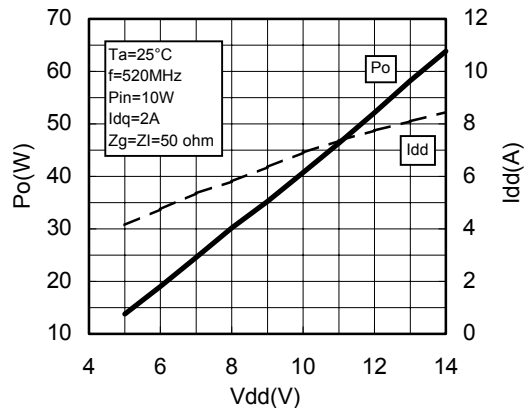



ELECTROSTATIC SENSITIVE DEVICE
OBSERVE HANDLING PRECAUTIONS

MITSUBISHI RF POWER MOS FET

RD70HVF1

Silicon MOSFET Power Transistor, 175MHz70W 520MHz,50W

TYPICAL CHARACTERISTICS

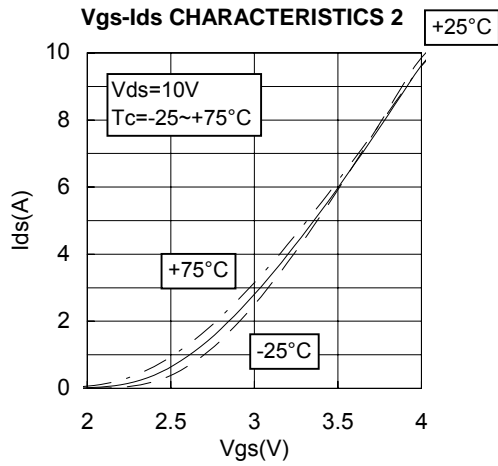

TEST CIRCUIT(f=175MHz)

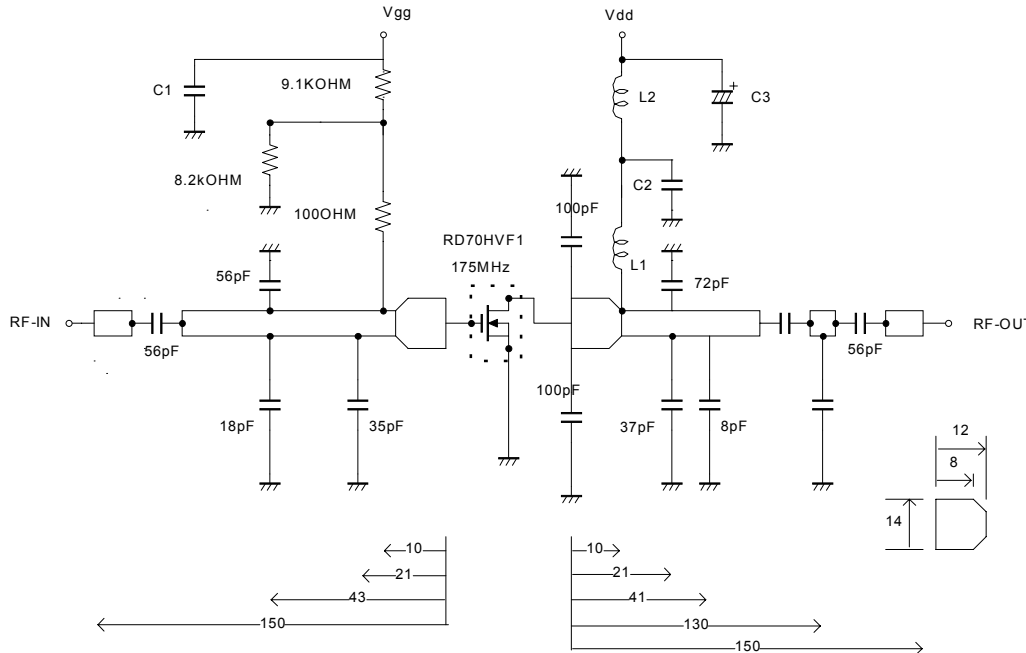

C1:2200pF,10uF in parallel

C2:2200pF*2 in parallel

C3:2200pF,330uF in parallel

L1:5Turns,I.D6mm,D1.6mm P=1 silver plated copper wire

L2:4Turns,I.D6mm,D1.6mm P=1 silver plated copper wire

Note:Board material-Teflon substrate

Micro strip line width=4.2mm/50OHM,er:2.7,t=1.6mm

Dimensions:mm



ELECTROSTATIC SENSITIVE DEVICE
OBSERVE HANDLING PRECAUTIONS

MITSUBISHI RF POWER MOS FET

RD70HVF1

Silicon MOSFET Power Transistor, 175MHz70W 520MHz,50W

TEST CIRCUIT(f=520MHz)

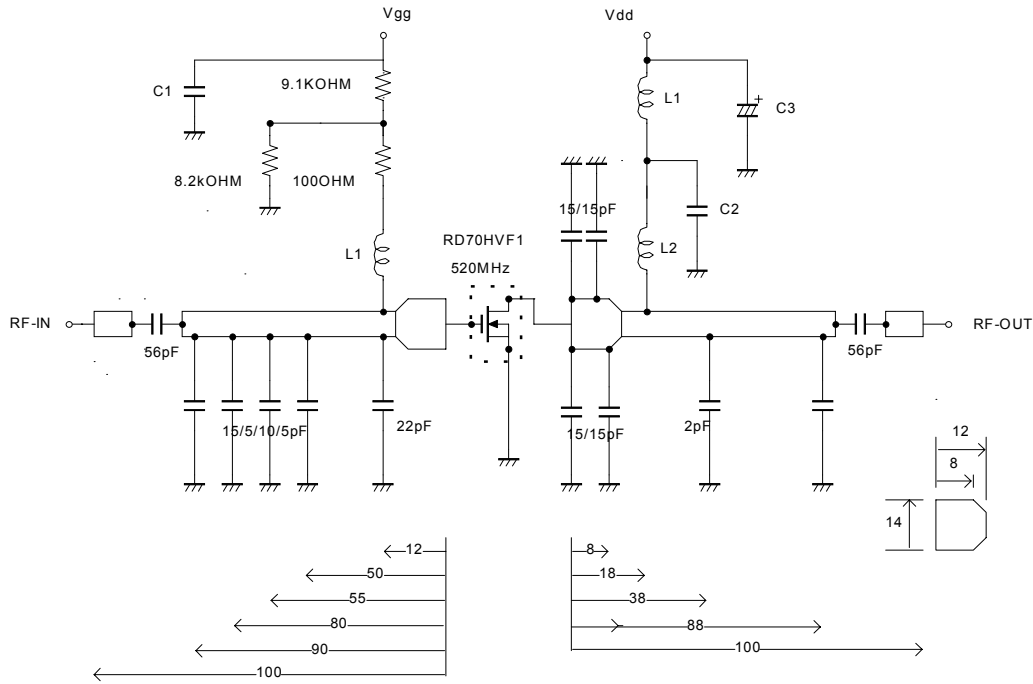

C1:2200pF,10uF in parallel

C2:2200pF*2 in parallel

C3:2200pF,330uF in parallel

L1:4Turns,l.D6mm,D1.6mm P=1 silver plated copper wire

L2:2Turns,l.D6mm,D1.6mm P=1 silver plated copper wire

Note:Board material-Teflon substrate

Micro strip line width=4.2mm/50OHM,er:2.7,t=1.6mm

Dimensions:mm



ELECTROSTATIC SENSITIVE DEVICE
OBSERVE HANDLING PRECAUTIONS

MITSUBISHI RF POWER MOS FET

RD70HVF1

Silicon MOSFET Power Transistor, 175MHz70W 520MHz,50W

INPUT/OUTPUT IMPEDANCE VS.FREQUENCY CHARACTERISTICS

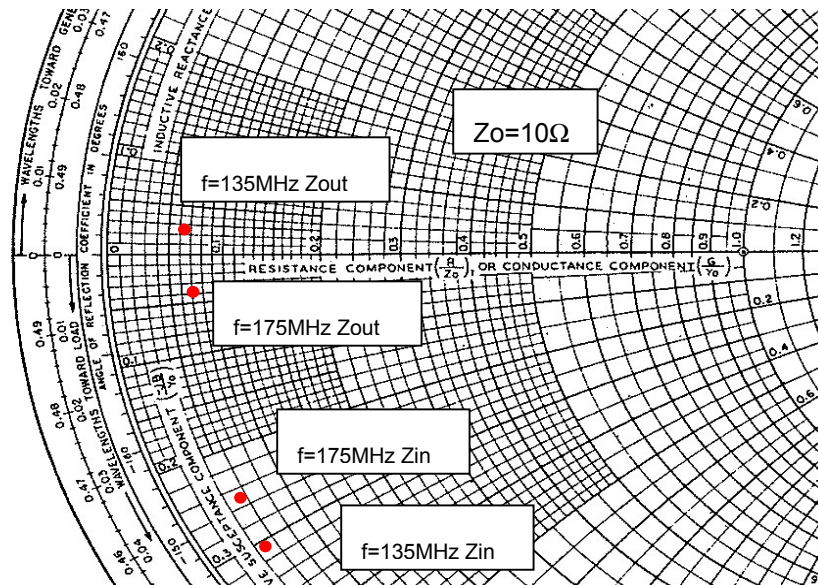

Zin, Zout

f (MHz)	Zin (ohm)	Zout (ohm)	Conditions
135	0.43-j3.19	0.70+j0.25	Po=90W, Vdd=12.5V, Pin=6W
175	0.55-j2.53	0.72-j0.36	Po=80W, Vdd=12.5V, Pin=6W

INPUT/OUTPUT IMPEDANCE VS.FREQUENCY CHARACTERISTICS

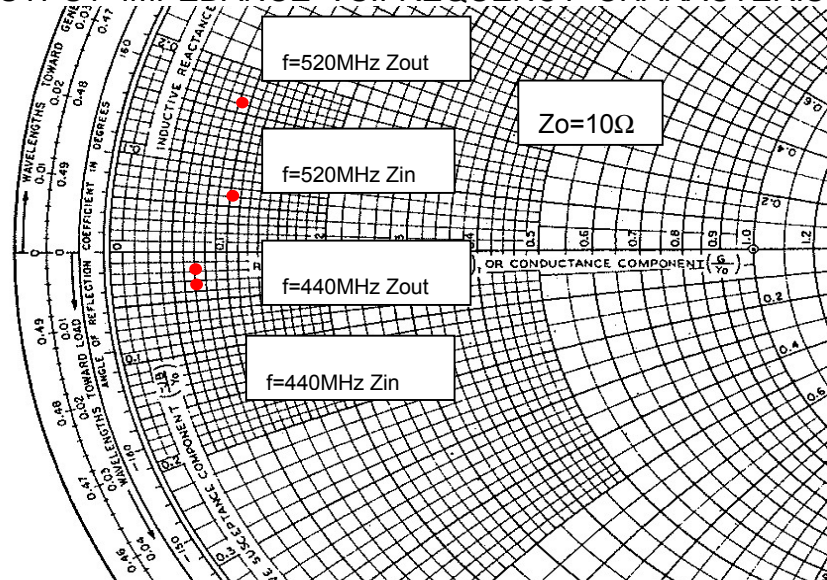

Zin, Zout

f (MHz)	Zin (ohm)	Zout (ohm)	Conditions
440	0.74-j0.34	0.71-j0.18	Po=60W, Vdd=12.5V, Pin=10W
520	1.04+j0.63	0.93+j1.62	Po=55W, Vdd=12.5V, Pin=10W



ELECTROSTATIC SENSITIVE DEVICE
OBSERVE HANDLING PRECAUTIONS

MITSUBISHI RF POWER MOS FET

RD70HVF1

Silicon MOSFET Power Transistor, 175MHz70W 520MHz,50W

RD70HVF1 S-PARAMETER DATA (@V_{dd}=12.5V, I_d=500mA)

Freq. [MHz]	S11		S21		S12		S22	
	(mag)	(ang)	(mag)	(ang)	(mag)	(ang)	(mag)	(ang)
50	0.885	-174.0	0.013	-16.2	8.441	72.4	0.745	-170.3
100	0.906	-176.8	0.011	-30.9	3.713	55.3	0.805	-170.5
150	0.930	-179.0	0.008	-39.5	2.095	41.2	0.860	-173.3
175	0.939	179.8	0.007	-44.3	1.647	35.9	0.874	-174.6
200	0.946	178.7	0.006	-46.6	1.337	32.3	0.897	-175.6
250	0.957	176.7	0.004	-46.5	0.908	24.8	0.933	-178.1
300	0.967	174.7	0.002	-40.8	0.661	19.4	0.935	179.4
350	0.969	173.0	0.001	-23.4	0.495	13.6	0.952	177.2
400	0.976	171.0	0.002	38.2	0.378	12.2	0.965	175.0
450	0.974	169.6	0.003	73.6	0.316	5.4	0.965	172.9
500	0.980	168.0	0.003	75.6	0.276	2.3	0.973	171.4
520	0.978	167.2	0.003	75.3	0.247	0.9	0.974	170.6
550	0.980	166.2	0.004	69.2	0.216	-0.2	0.975	169.5
600	0.980	164.6	0.005	74.3	0.176	-1.5	0.974	167.8
650	0.982	163.3	0.007	79.3	0.156	-1.4	0.979	166.3
700	0.985	162.0	0.007	75.4	0.126	-3.3	0.983	164.9
750	0.982	160.7	0.007	76.7	0.108	-2.0	0.982	163.6
800	0.982	159.4	0.009	77.1	0.106	-1.1	0.984	162.0
850	0.984	158.1	0.009	72.6	0.107	-9.0	0.989	160.9
900	0.983	157.0	0.010	72.1	0.078	-13.4	0.983	159.6
950	0.984	155.9	0.011	74.4	0.079	-4.5	0.987	158.2
1000	0.985	154.6	0.011	72.7	0.067	-5.3	0.993	157.3



ELECTROSTATIC SENSITIVE DEVICE
OBSERVE HANDLING PRECAUTIONS

MITSUBISHI RF POWER MOS FET

RD70HVF1

Silicon MOSFET Power Transistor, 175MHz70W 520MHz,50W

Keep safety first in your circuit designs!

Mitsubishi Electric Corporation puts the maximum effort into making semiconductor products better and more reliable, but there is always the possibility that trouble may occur with them. Trouble with semiconductors may lead to personal injury, fire or property damage. Remember to give due consideration to safety when making your circuit designs, with appropriate measures such as (i) placement of substitutive, auxiliary circuits, (ii) use of non-flammable material or (iii) prevention against any malfunction or mishap.